

SECTION A-A
SCALE 1 : 1

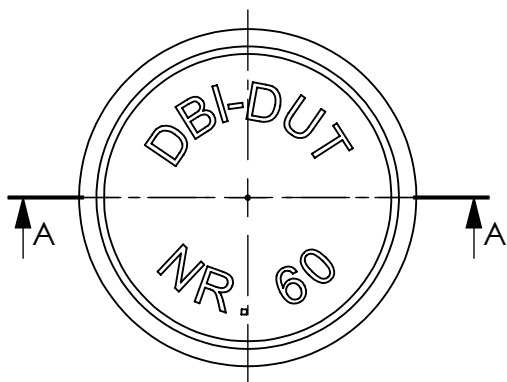

REVISIONS			
REV.	DESCRIPTION	DATE	AUTHOR
1	Drawing is according to measurement report per 11-05-2005.	21-06-2005	KV
2	Dimension is adjusted according to measurement report per 22-06-2006	22-06-2006	KPE
3	Part number changed from 410060 to NA0400A-AA. Tolerances added.	20-11-2007	KV
4	In comments: NA0400D-AA changed to NA0400L-AA	17-06-2008	TGJ
5	Drawing is according to measurement report per 03-12-2009.	17-12-2009	KV
6	Drawing is according to measurement report per 30-03-2012.	02-04-2012	KV

Cavity number

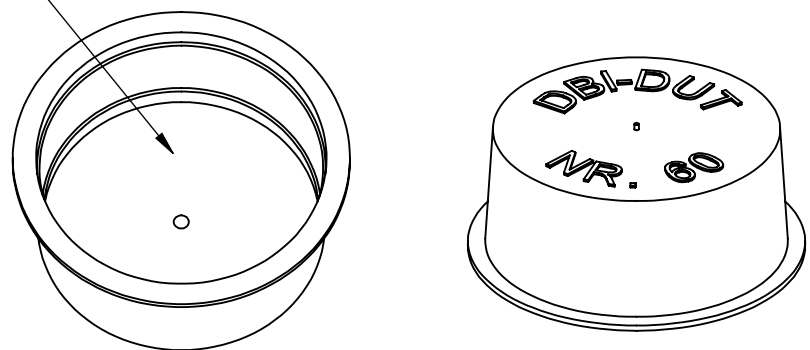

Actual size.

Comment:
Drawing is according to the latest measurement report.

Comment:
Drawing is valid for caps both with (NA0400L-AA) and without vent hole (NA0400A-AA). Furthermore drawing is valid for caps with UV-treatment (NA0400A-AU).

Sheet: A4	Scale: 1:1	DBI A/S Project No: 02529	Drawing: NA0400A-AA
Material: PELD	Colour: All	DBI A/S Product No: NA0400A-AA	
Part Weight: 2,6 g	Part Surface Area: 72,59 cm ²	Product Name: Conical cap 0400	
			Dimensions are given in mm. Dimensions without tolerances according to DS 812 / DIN16901
			This drawing belongs to DBI Plastics A/S and may not be used or shown without permission.