



Frost detectors

QAF63.2-J
QAF63.6-J

for use on the air side

-
- **Active capillary tube sensor for acquiring the lowest temperature within a range of 0...15 °C**
 - **Operating voltage AC 24 V**
 - **Signal output DC 0...10 V**

Use

On the air side of ventilation and air conditioning plants:

- Typically: hot water air heating coils where there is a risk of freezing due to cold incoming outside air
- Where fans are to be switched off, heating valves opened, air dampers closed or other actions need to be taken by the control system to prevent freeze-ups

Functions

Technical design

With the help of a vapor-filled capillary tube and diaphragm, the QAF63.. acquires the lowest temperature which occurs along at least 250 mm length of capillary tubing.

If the frost detector is correctly located at the air outlet of the air heating coil, it acquires the lowest air temperature even in the case of temperature stratification. The vapor pressure in the capillary tube produces a certain diaphragm travel. This

movement is converted to an electric signal with the help of an inductive measuring system. It is then electronically amplified so that a DC 0...10 V measuring signal can be produced (terminal B).

To make certain it is always the lowest temperature along the capillary tube that is acquired, the temperature of the diaphragm inside the housing must always be higher than the temperature at the capillary tube. This is ensured by a heating element inside the housing, which maintains the temperature at the diaphragm above 15 °C as long as the ambient temperature does not fall below -15 °C.

Mechanical design

The frost detector consists of a two-sectional housing (base and cover) and a capillary tube which is active over its full length.

The cover is secured to the base with a fixing screw and can be removed.

The housing accommodates the electronics, the diaphragm with the heating element, the connection terminals and the type field.

Connection terminals and type field can be accessed after removing the cover.

The cables are introduced to the housing from below. There is one hole for the enclosed cable gland M16, and 2 knockout holes for additional cable glands M16.

The QFA63... can be fitted directly to the wall – with or without a test loop – or with the help of a mounting flange (if the air duct is insulated).

Type summary

<i>Product number</i>	<i>Stock number</i>	<i>Description</i>
QAF63.2-J	S55700-P153	Frost unit with 2-m capillary
QAF63.6-J	S55700-P154	Frost unit with 6-m capillary

Ordering

When ordering, please give product number, stock number and description.

The mounting accessories not included in the scope of delivery must be ordered as separate items.

Accessories

Included in the scope of delivery

- 1 x M16 cable gland for cable entry
- 2 x screw to DIN 7981-St 4.2 x 22 for direct mounting
- 1 x rubber grommet for capillary entries into air ducts (4 109 2106 0)

Not included in the scope of delivery

<i>Product number</i>	<i>Stock number</i>	<i>Designation</i>	<i>Parts</i>
AQM63.0	BPZ:AQM63.0	Mounting flange	1 x depth-adjustable mounting flange for the housing
AQM63.2 ¹⁾	BPZ:AQM63.2	Capillary support	3 x capillary tube clamp 3 x spacer

1) QAF63.6-J requires 2 AQM63.2

Notes

Engineering

The frost detector operates on AC 24 V. The transformer used must be suitable for safety extra low voltage (SELV), 100% duty, and must have separate windings.

Fuses, switches, wiring and earthing must be in compliance with local safety regulations. The permissible cable lengths must be observed.

If the capillary tube is mechanically damaged or if there is a leak in the diaphragm system, the frost detector signals a temperature of 0 °C. That is the case also if there is a power failure or if one of the major electronic components fails.

Mounting

Mounting location

On the hot side of the air heating coil.

Mounting of housing

Direct mounting

Fit the housing (by using the 2 fixing holes) to the wall of the air heating coil. Introduce the capillary tube in the air duct and protect it by using the rubber grommet supplied with the frost detector (refer to "Accessories").

When fitting the frost detector inside the air duct: secure the housing to the inner wall of the air heating coil and lead the capillary tube through one of the lateral grooves.

Direct mounting, with test loop for functional test

Fit the housing (by using the 2 fixing holes) to the wall of the air heating coil and lead the capillary tube through one of the lateral grooves.

Bend the capillary to form a test loop, introduce the capillary to the air duct and protect it by using the enclosed rubber grommet (refer to "Accessories").

This mounting method is not recommended when the ambient temperature at the external test loop may fall below the temperature at the measuring location in the air duct (the measuring signal of the sensing element always represents the lowest temperature, no matter where it occurs along the capillary tube!).

With mounting flange (refer to "Accessories")

This mounting method is suited for air ducts having an insulation of up to 70 mm.

Fit the mounting flange to the wall of the air heating coil and introduce the capillary tube through the flange in the air duct.

Fitting the capillary tube

Coil the capillary tube evenly across the entire cross-sectional area of the air heating coil and attach it to the coil with the help of the clamps, maintaining a spacing of 40 mm (refer to "Accessories").

 CAUTION

The capillary tube must not be sharply bent. The bending radius should be as great as possible.

Installation

The connection terminals are protected against wiring errors with own voltages up to AC 24 V.

Commissioning

There are no settings required on the frost detector.

Using a test loop, the correct functioning of the frost detector can be checked with the help of a mixture of ice and water.

Disposal



The frost detectors are considered electronics devices for disposal in terms of European Directive 2012/19/EU and may not be disposed of as domestic waste.

- Dispose of the Device via the channels provided for this purpose.
- Comply with all local and currently applicable laws and regulations.

Technical data

Power supply	Operating voltage	AC 24 V \pm 20% (SELV)
	Frequency	50/60 Hz
	Power consumption	5 VA
	At ambient temperatures >10 °C (with no heating)	2.5 VA
External supply line protection	Circuit breaker max. 10 A Characteristic B, C, D according to EN 60898 or Power source with current limitation of max. 10 A	
Line lengths for measure signal terminals B - M	Perm. cable length	
	Copper cable 1.5 mm ²	300 m
Functional data	Measuring range	0...15 °C
	Time constant	
	In still air	Approx. 90 s
	In moving air	<40 s
	Output signal, linear (terminal B)	DC 0...10 V $\hat{=}$ 0...15 °C Max. \pm 1 mA
	Capillary tube	
Min. active length	250 mm	
Perm. temperature	Max. 110 °C	
Degree of protection	Housing	IP42 to EN 60529
	Protection class	III
Electrical connections	Screw terminals for	2 x 1.5 mm ² or 1 x 2.5 mm ²
	Cable entry	M16 cable gland
Environmental conditions	Operation	IEC 721-3-3
	Climatic conditions	
	Temperature	-15...55 °C
	Humidity	<85% r.h.
	Storage/transport	IEC 721-3-2
	Climatic conditions	Class 2K3
Temperature	-25...65 °C	
Humidity	<95% r.h.	
Mechanical conditions	Class 2M2	
Materials and colors	Base	Wellamid 6600 HWC8, RAL 7001 (silver-grey)
	Cover	PC Lexan 161R (transparent)
	Mounting flange	PA 66 (black)
	Capillary tube	Copper
	Packaging	Corrugated cardboard
Directives and standards	Product standard	EN 61326-x
	EU Conformity (CE)	8000036002 ^{*)}
Weight	QAF63.2-J	Approx. 0.32 kg
	QAF63.6-J	Approx. 0.39 kg

^{*)} The documents can be downloaded from <http://siemens.com/bt/download>

Diagrams

Internal diagram

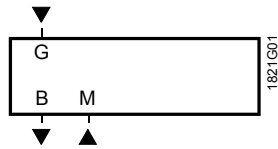

- G System voltage (SELV) AC 24 V
- M System neutral, measuring neutral
- B Signal output DC 0...10 V $\hat{=}$ 0...15 °C

Dimensions

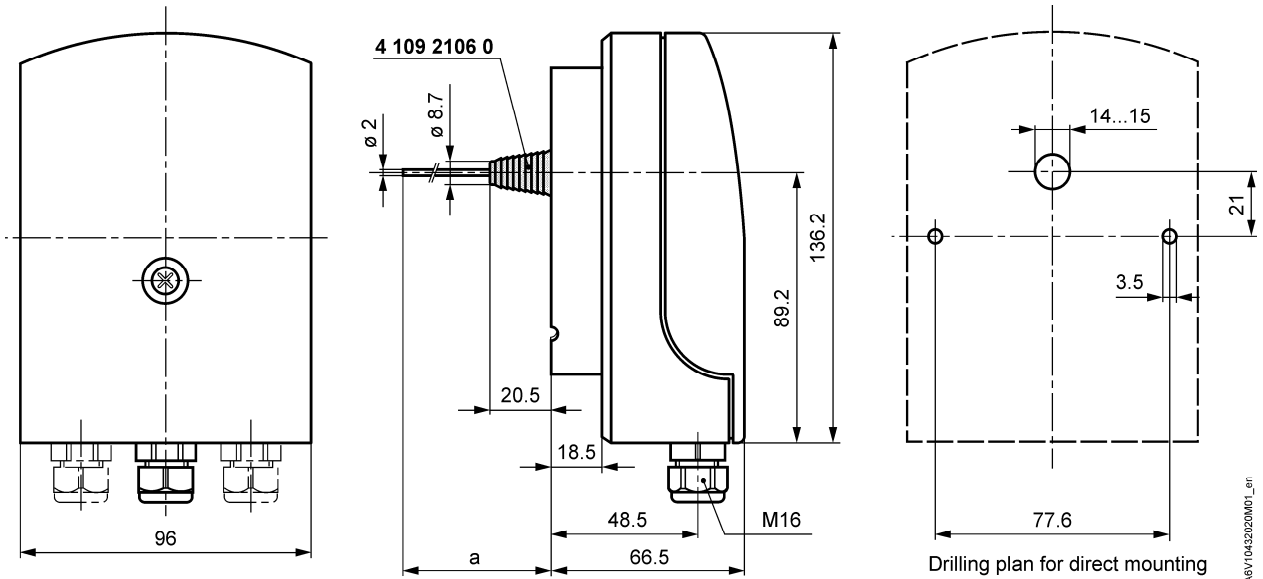

(Dimensions in mm)

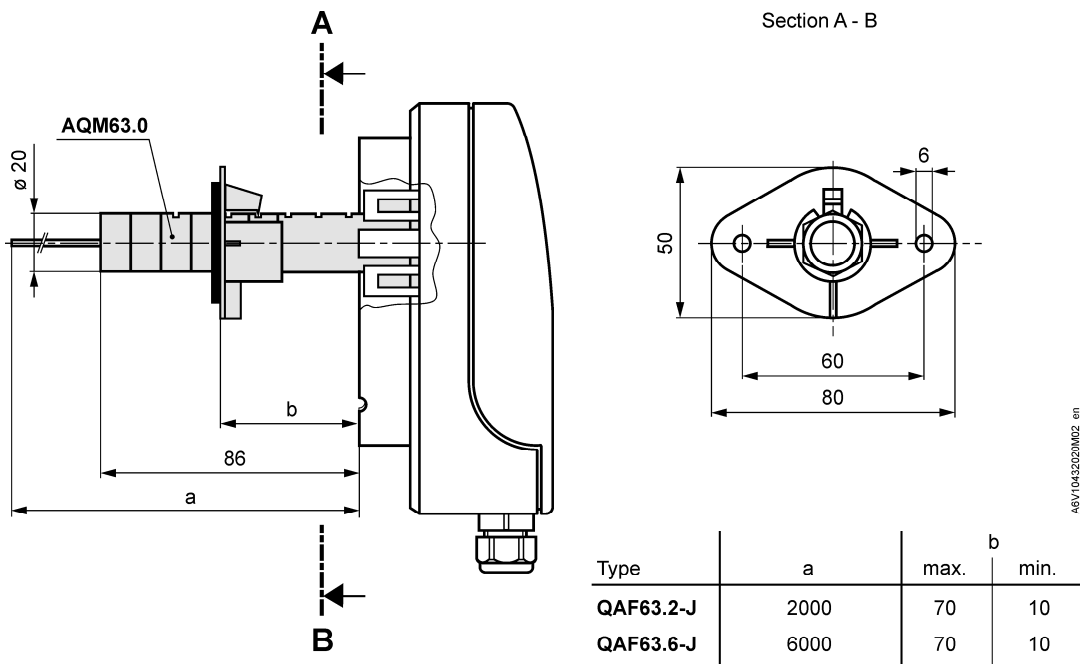

Type	a	max.	min.
QAF63.2-J	2000	70	10
QAF63.6-J	6000	70	10

QAF63... with depth-adjustable mounting flange AQM63.0

(Dimensions in mm)

